



Operational Excellence in a fast changing environment

Kurt Haerri, Senior Vice President
Schindler Group

March 23rd 2017



Die Welt verändert sich

Emerging Markets will dominate the world's economy within the next decades

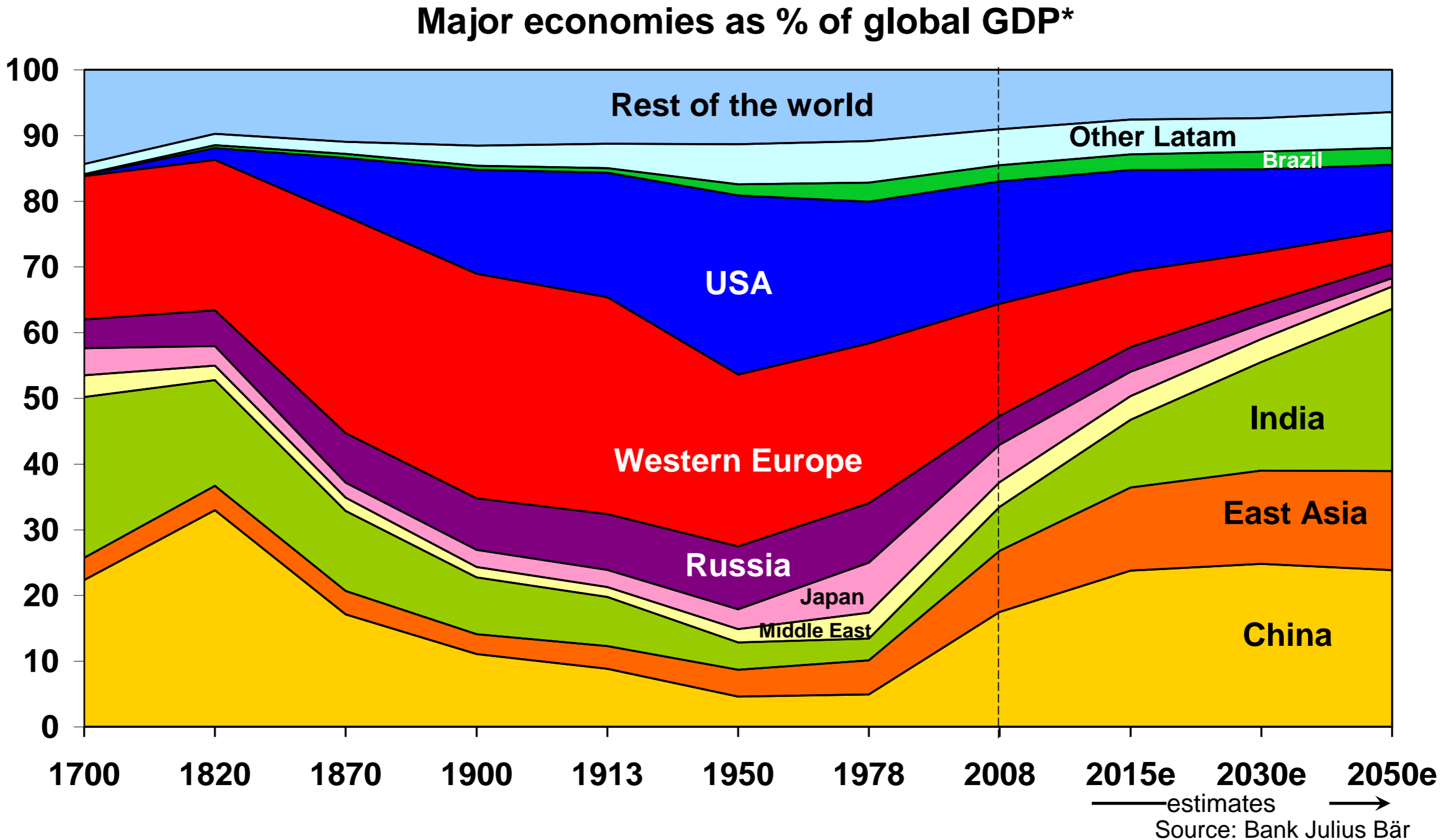

Preisschild des iPhone Ladekabels

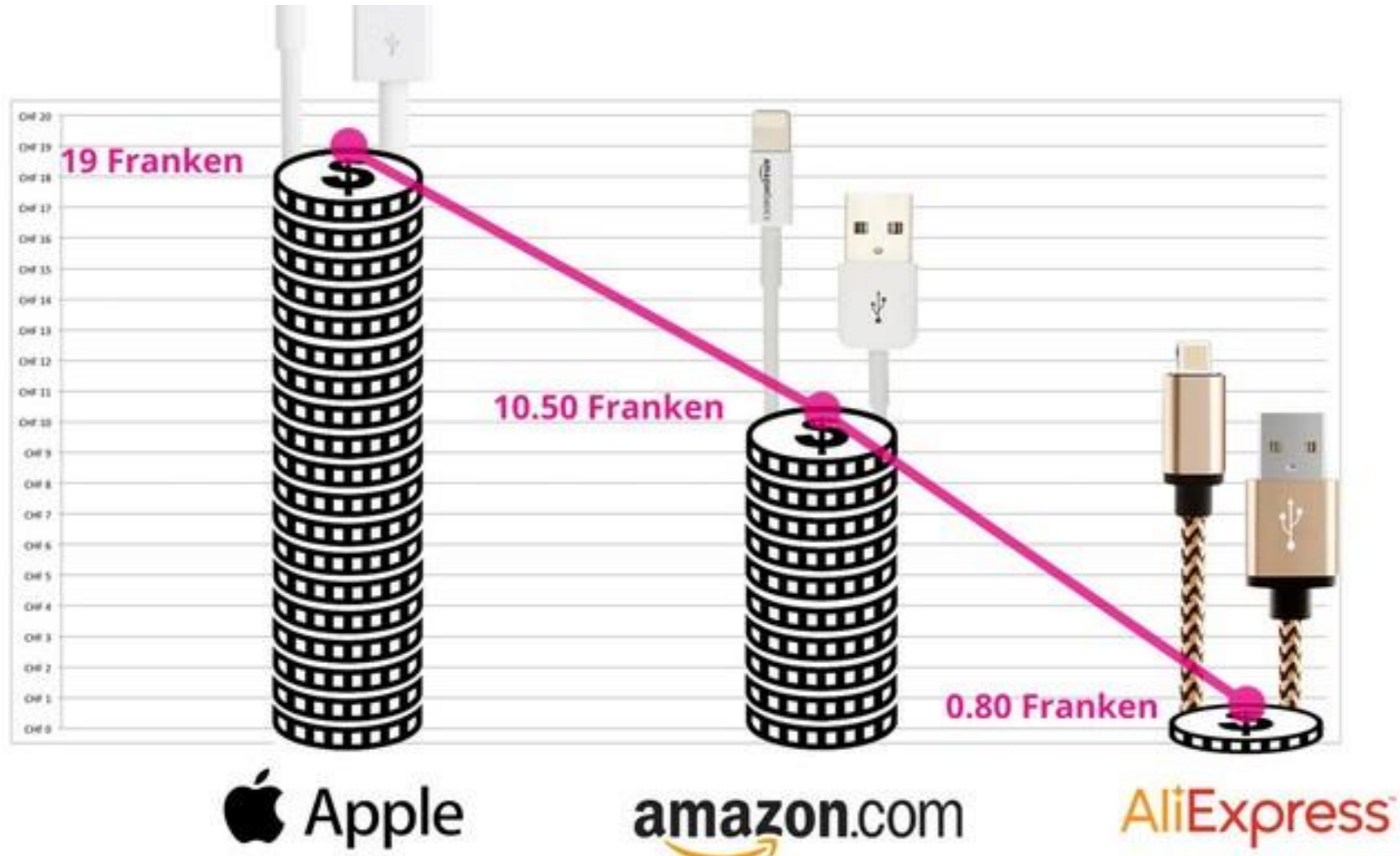

China: 3,6 Mio Couples got divorced in 2014

Handelszeitung

Hohe Scheidungsrate beschleunigt das Schindler Geschäft in China

April 25th 2016

Wachstumsmarkt

Realität in China: Wenn zwei sich streiten, lacht der Dritte. Umso mehr Singles China hat, umso mehr Wohnungen werden gebraucht. **Und die brauchen Aufzüge!**



Perception of the New World

Wie nehmen wir China wahr „China“?

Als ein grosses Risiko?



Als eine Chance?



Tolle Schindler Referenz-Projekte in China



Ping An Finance Center
Shenzhen
China
660 m



Tencent Seafront Tower
Shenzhen
China
192 m



Qingdao Center
Qingdao
China
245 m



International
Commerce Center
Hongkong
490 m

The challenge for Schindler

Schindler Group

Global presence

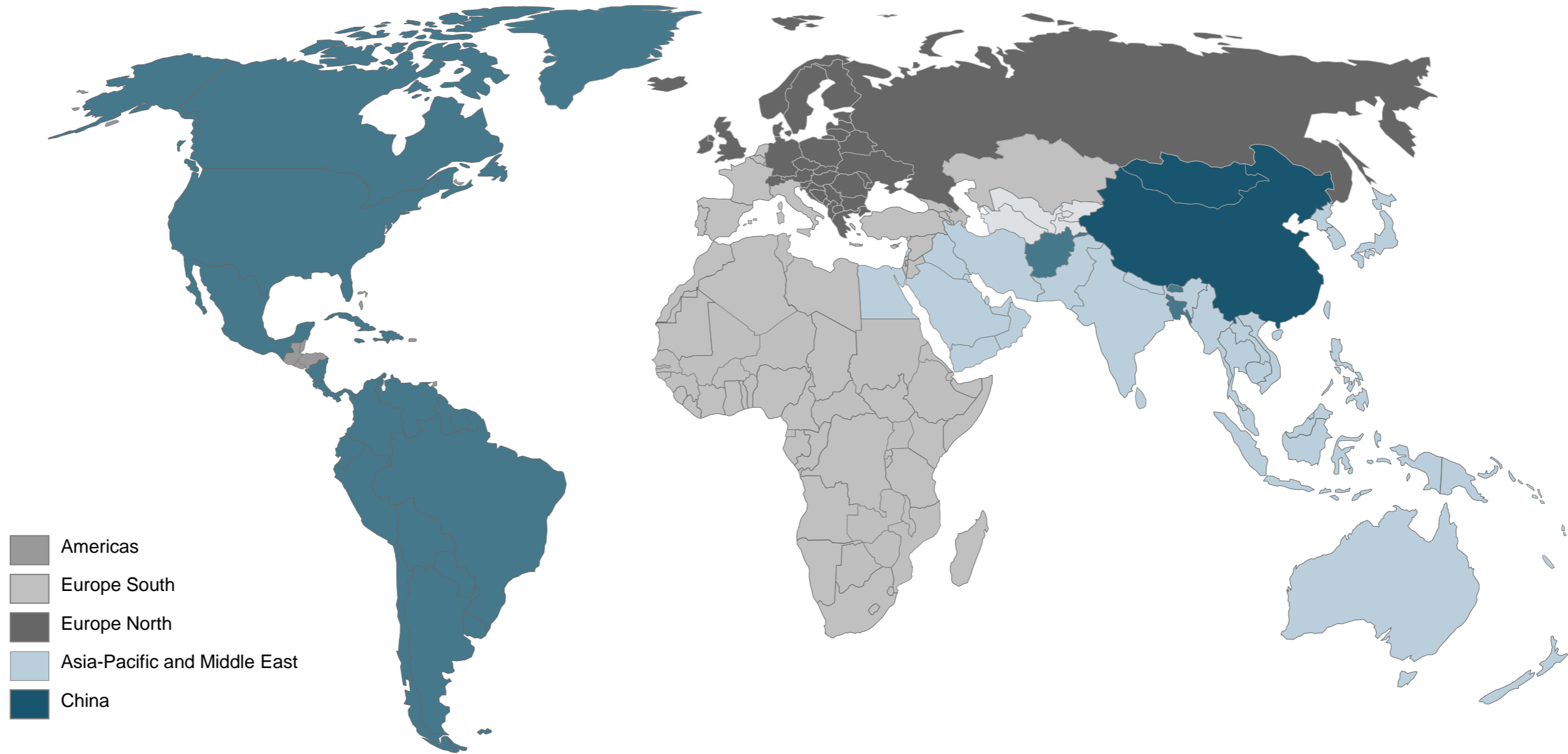

more than 58,000 employees – more than 100 countries – more than 1,000 branches

Global Elevator & Escalator Market

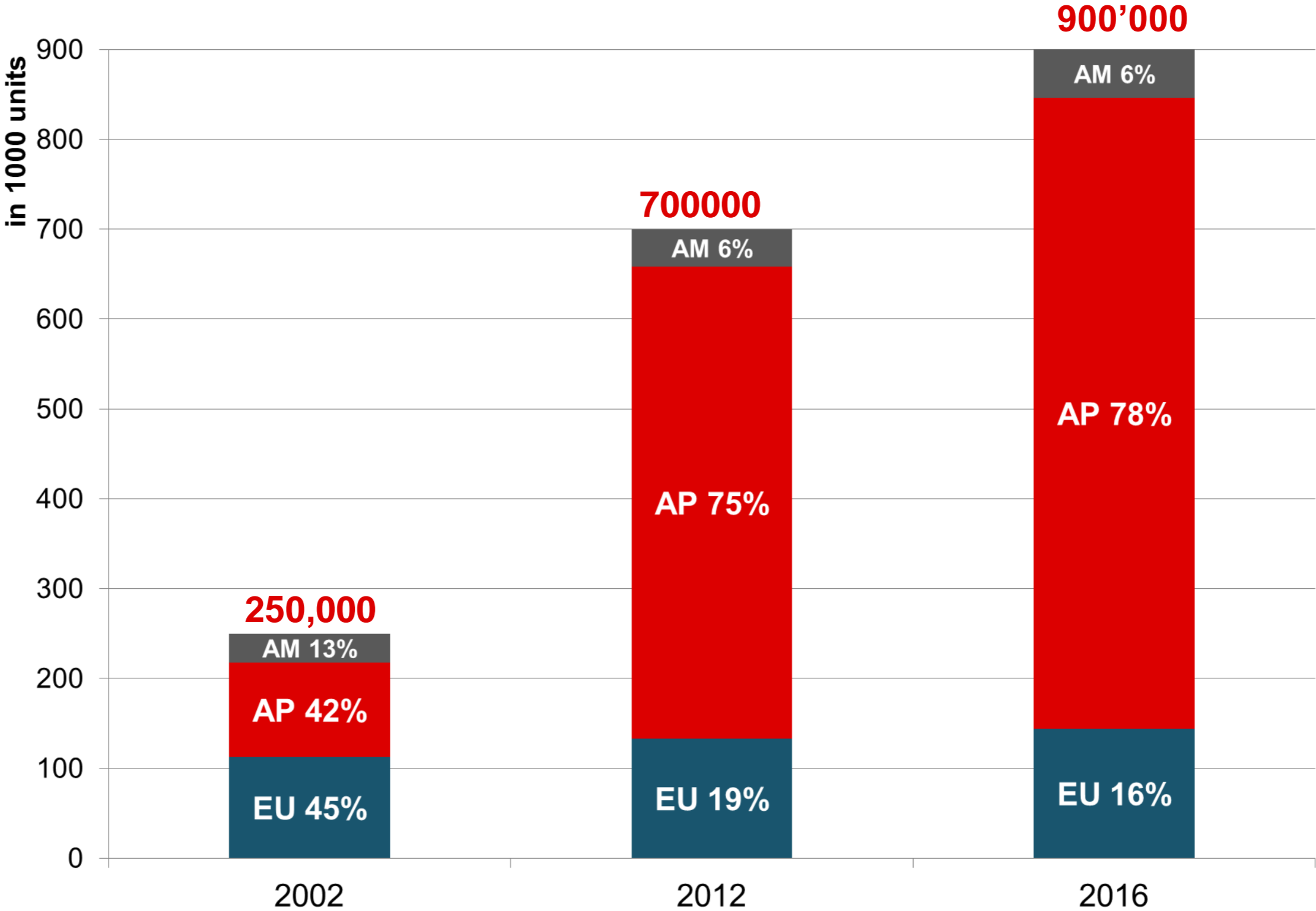

2012: Global cement production: 3.6 billion tons

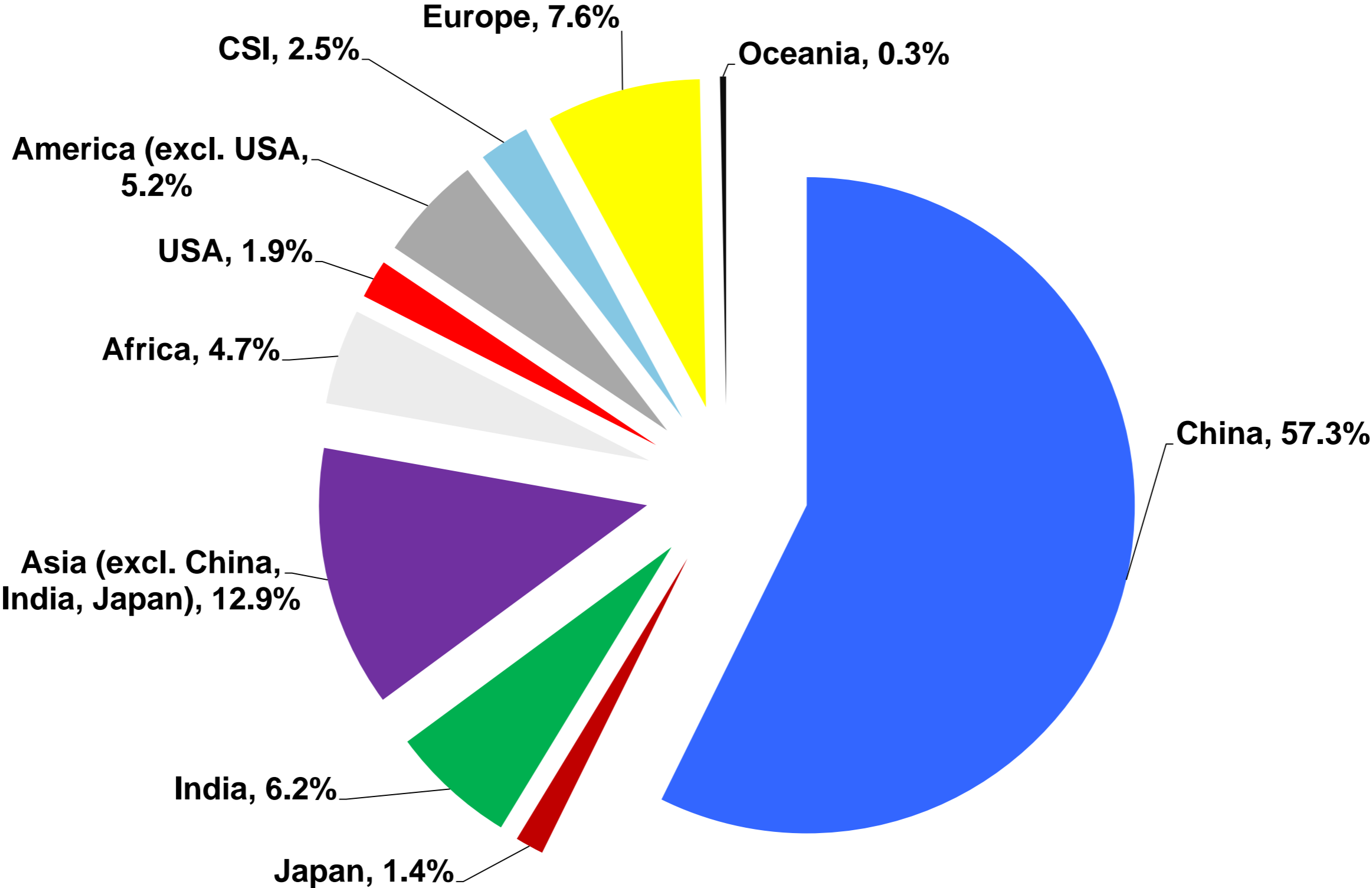

Source: Holcim

International Commerce Centre, Hong Kong – China

Office building & Hotel – Height: 490 m



Project Summary:

- 56 High Rise elevators (40 double deck units)
- Total project volume: 106 Schindler elevators and escalators
- Project cost approx. 40 Mio. USD
- Project duration approx. 5 years
- Over 20,000 will be working in this building.

5 Largest Markets for Elevators and Escalators



Total Market New Installations (2013)

Elevator Density

Emerging Markets with large Growth Potential

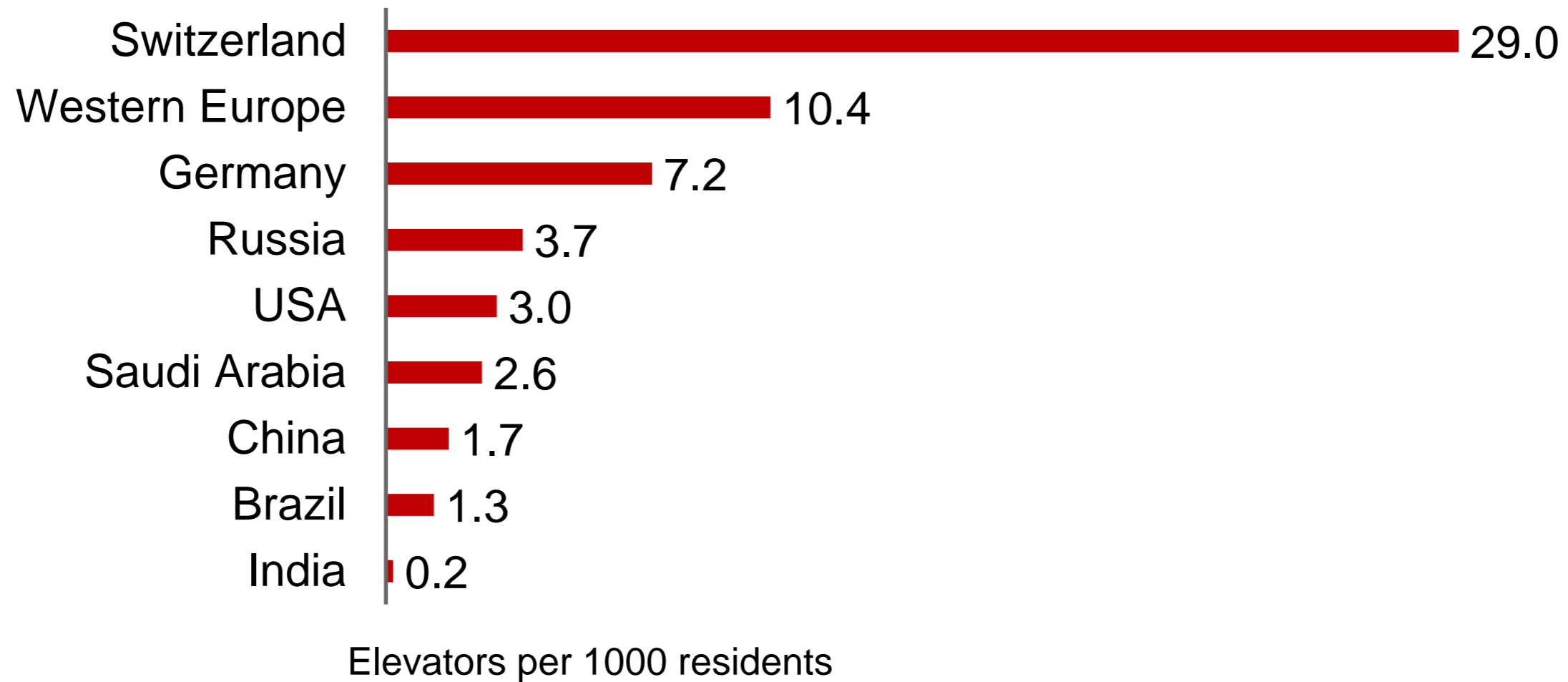

Are we ready for the new markets?

China: Market segmentation

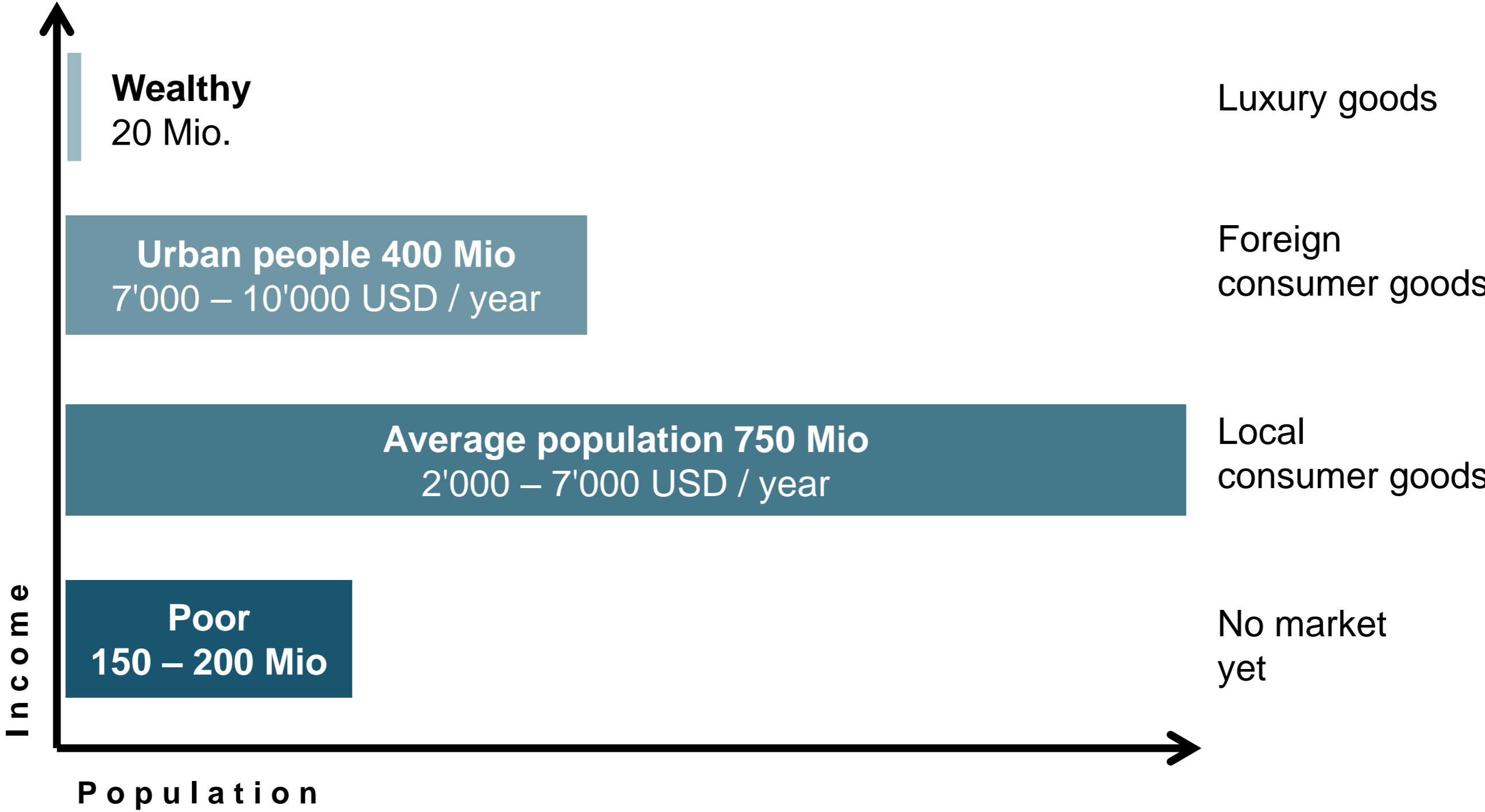

China Auto Market Status and Tendency/CHINA

In 2015, the Chinese vehicle sales is 24.60 million, and the YOY growth is 4.7%. Chinese passenger vehicle sales is 21.15 million, and YOY is 7.3%. Chinese commercial vehicle sales is 3.45 Million, and the YOY is **-9.0%**. Chinese vehicle market was effect by several factors:

- Chinese stock market and national economic.
- Government policy incent such as the policy that purchasing tax of passenger vehicle under 1.6L is decreased to half since 2015 Oct.

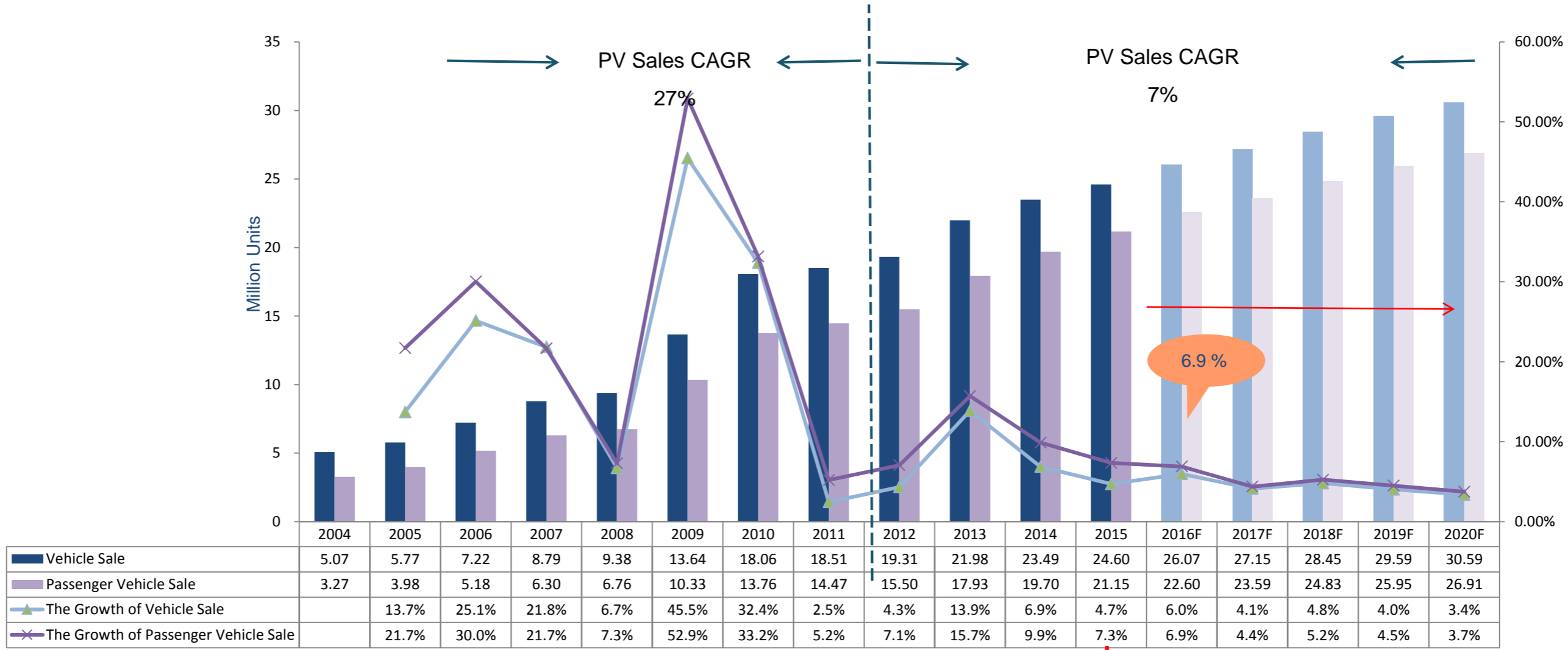

Source: CATARC(China Automotive Technology and Research Center), 201601
 Notes: CAGR (Compound Annual Growth Rate)
 Notes: New Normal: More stable and slower growth than before

China's Urbanization & Infrastructure

Shanghai Metro System - 2000



No. of lines:
3

Length of network:
Approx. 65 km

Shanghai Metro System - 2006



No. of lines:

5

Length of network:
approx. 190 km

Shanghai Metro System - 2011

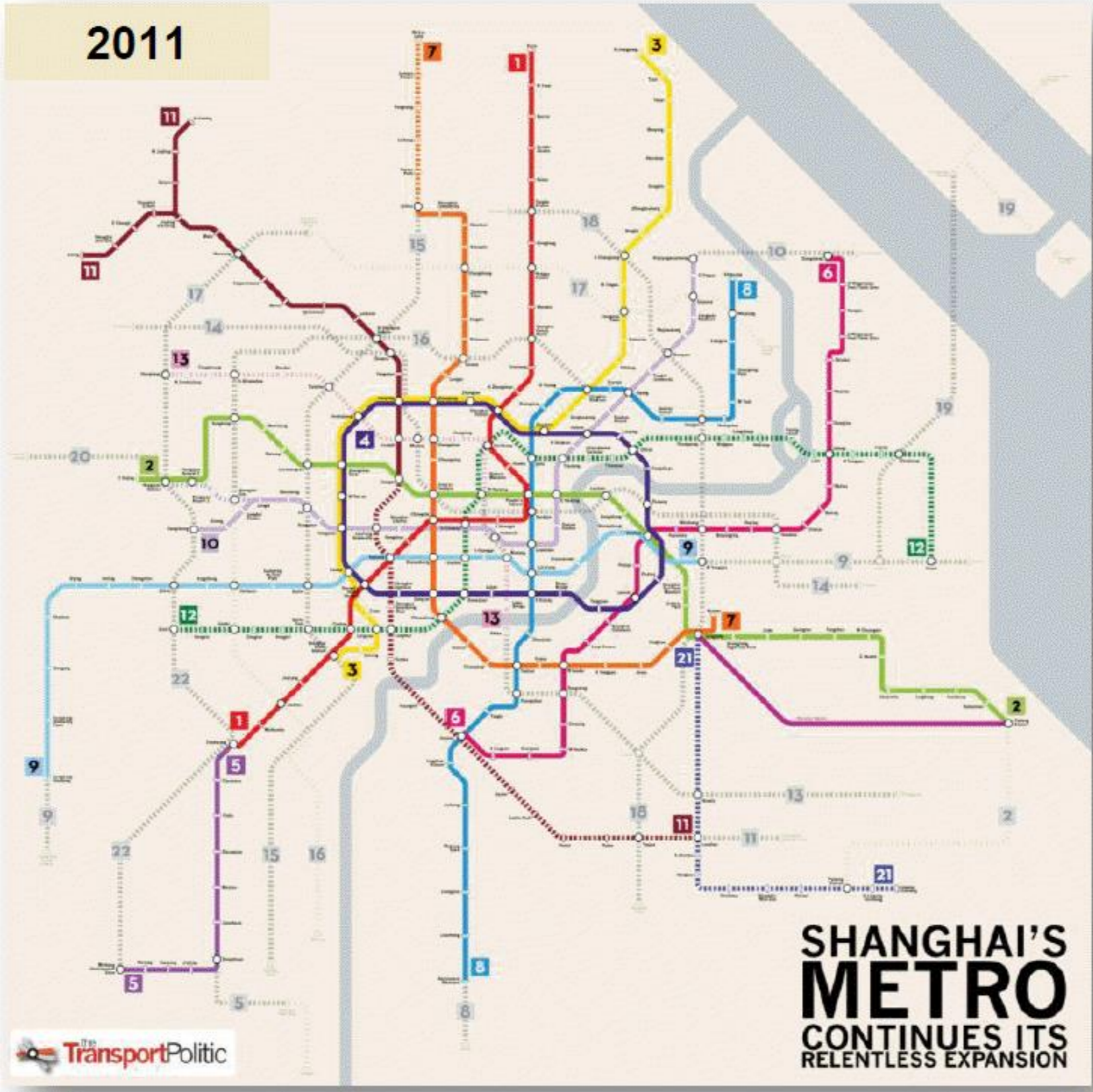

No. of lines:
12

Length of network:
approx. 420 km

(London : 408 km,
New York : 368 km)

Shanghai Metro System - 2020

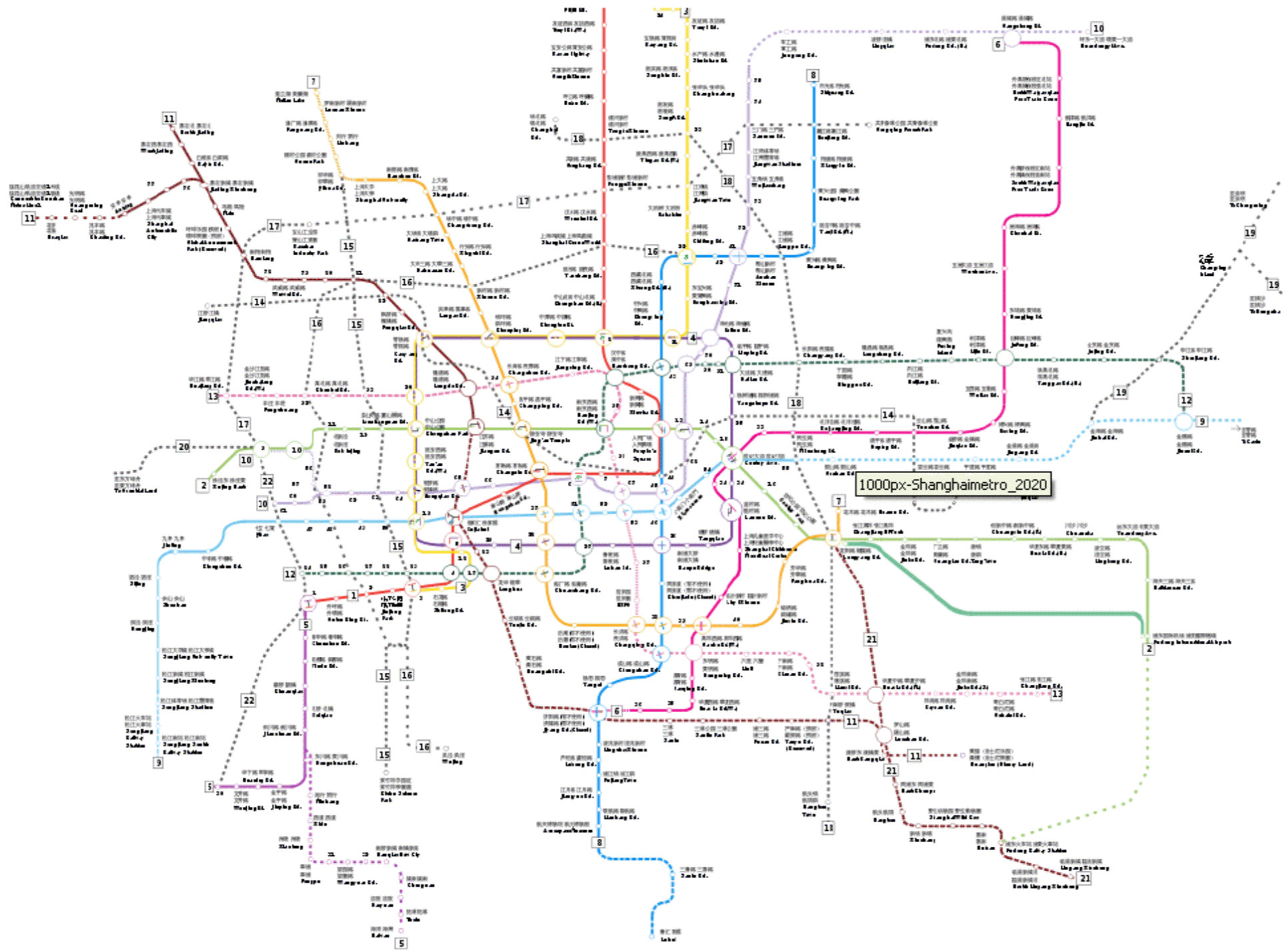

No. of lines:
22

Length of network:
approx. 970 km

The Schindler answer

Strategic steps since 1982

1. Critical mass: growth and focus

2. Continental platforms

3. Global platform

Schindler Group

New world-class manufacturing facilities (as of December 31, 2015)

- Proximity to strategic markets
- Global platforms
- State-of-the-art process
- Rationalized supplier base
- Economies of scale

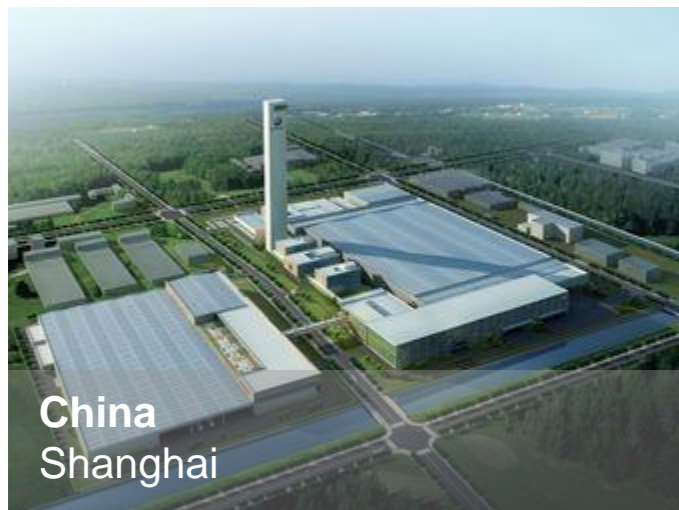

Plot size: 315 000 m²

- Elevator factory
- Escalator factory
- Test Tower
- Next step: R&D Center,
Schindler City and Step plant



Plot size: 75 000 m²

- Escalator factory
- Elevator factory
- Logistics Center



Plot size: 160 000 m²

- Elevator factory
- R&D Center
- Test Tower
- Next step: Escalator factory



Plot size: 14 000 m²

- Elevator factory
- Logistics Center

New Schindler Campus in Shanghai / Jiading

Plot size: 315'000 m² (approximately 44 soccer fields)

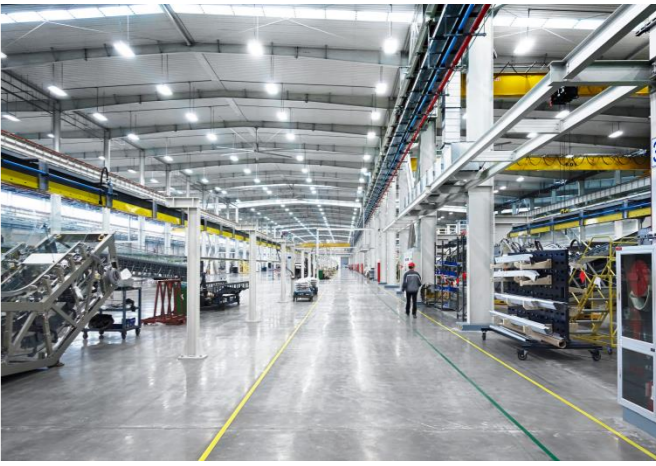

Schindler Group

Manufacturing sites elevators & escalators



Next steps

- Escalator factory in Pune (2017)

Continental platforms

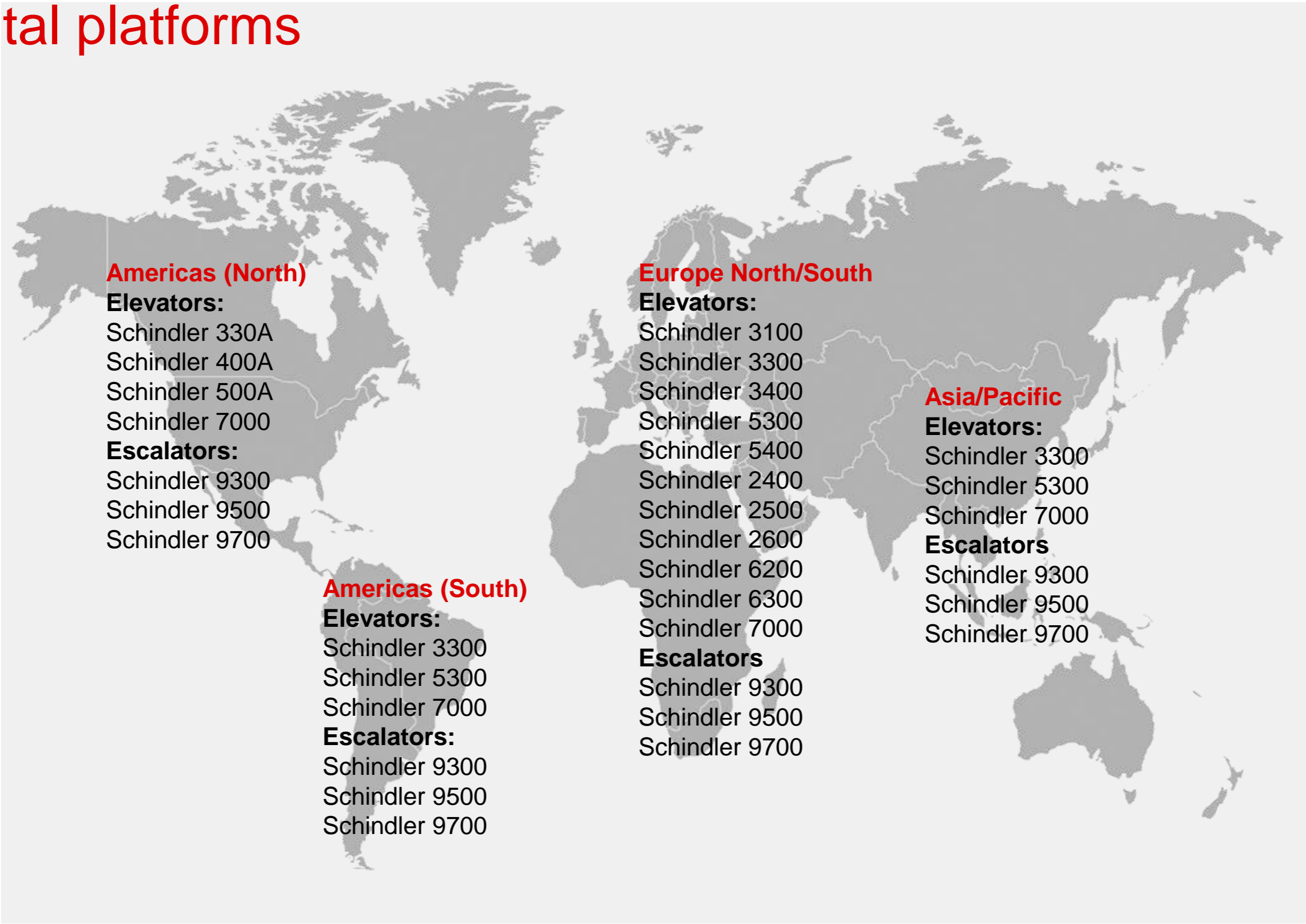

Continental sourcing

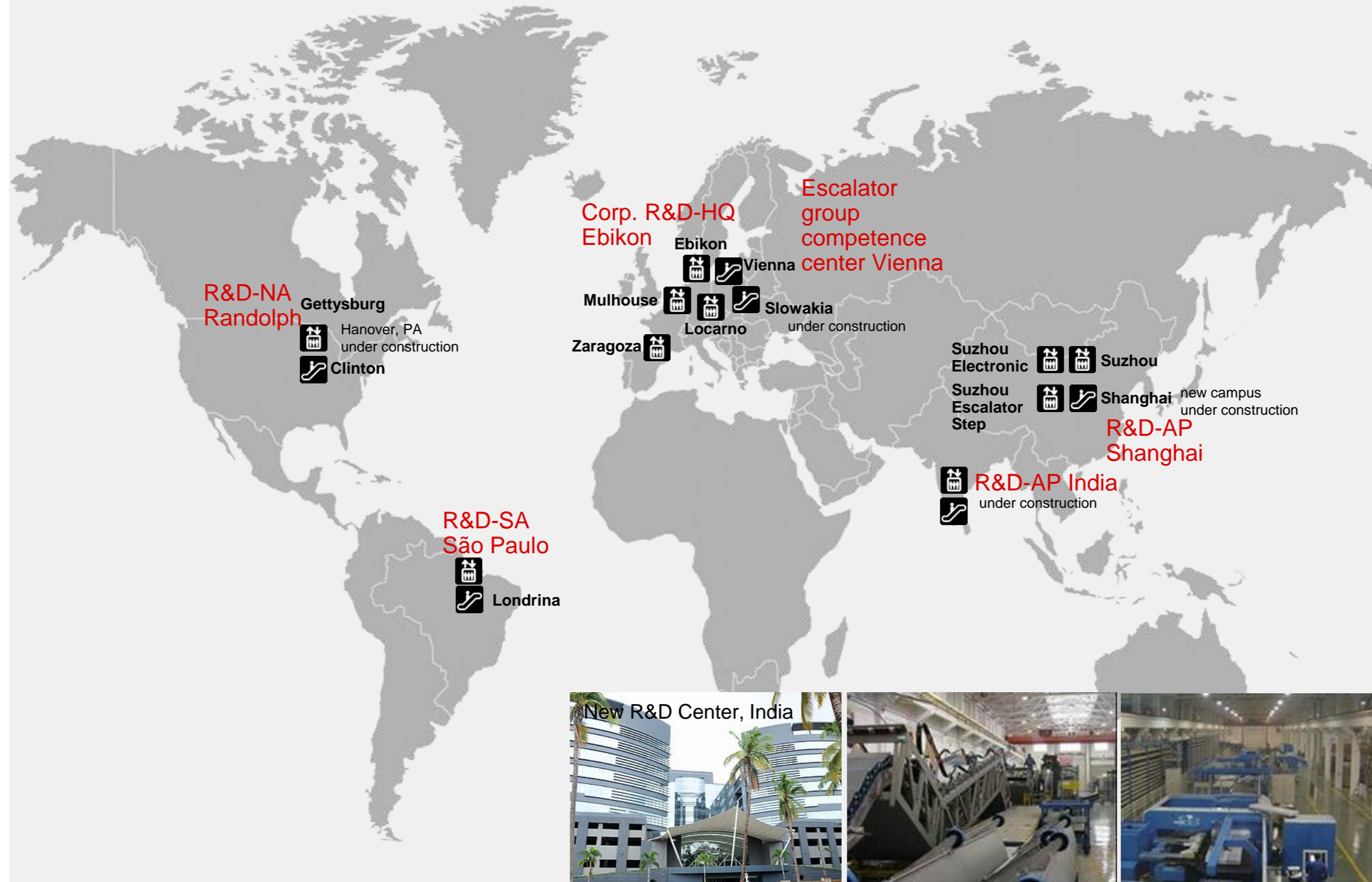

Harmonization of Products Optimized Supply Chain

What else is needed to be competitive?

30% of our value chain is at the
construction sites

Freedom Towers New York



49er Stadium San Francisco



Costanera Center Santiago, Chile



Lodha Tower Mumbai



Installation Platforms

Different available solutions

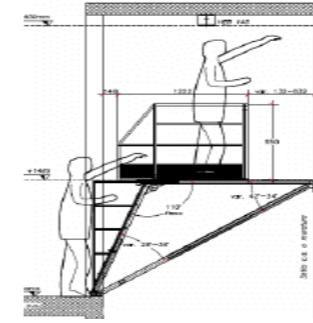
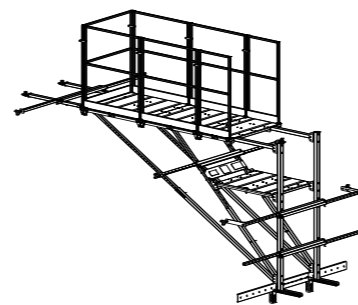
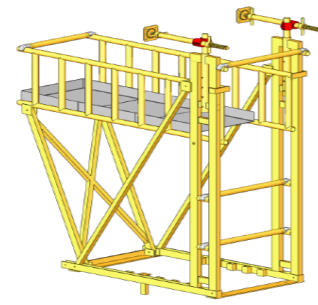

Name	M&M	TP-4	Decks	MIL (Italy)	PAR (France)
Developed	Schindler	Schindler	Constructor	Schindler	Schindler PAR
Type	Cantilever	Front support	Side support	Front support	Cantilever

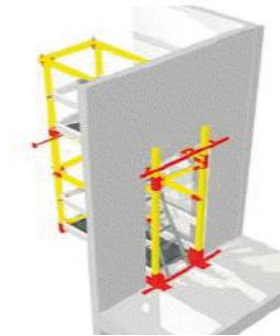

Name	Pano	Elescaf	Compact	SCS	Work Deck
Developed	Stingl	Tractel	Aire Valley	SCS	Wurtec
Type	Cantilever/ Front support	Cantilever	Cantilever	Cantilever	Front support

Project Scope & Objectives "INEX"

Standardisation of Installation Tools

METHOD TOOLS MAINTENANCE LOGISTIC



Only One Platform

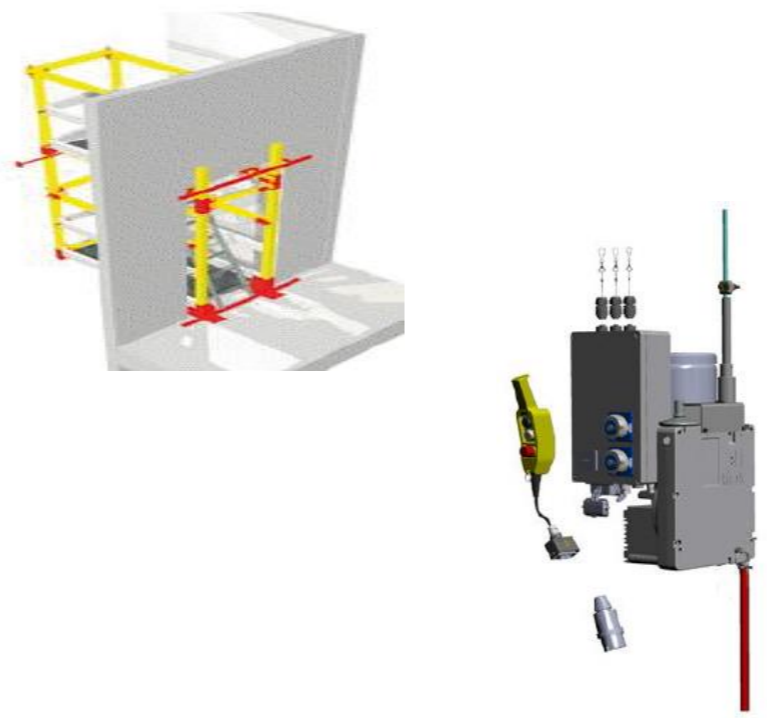

Only One Hoist Type

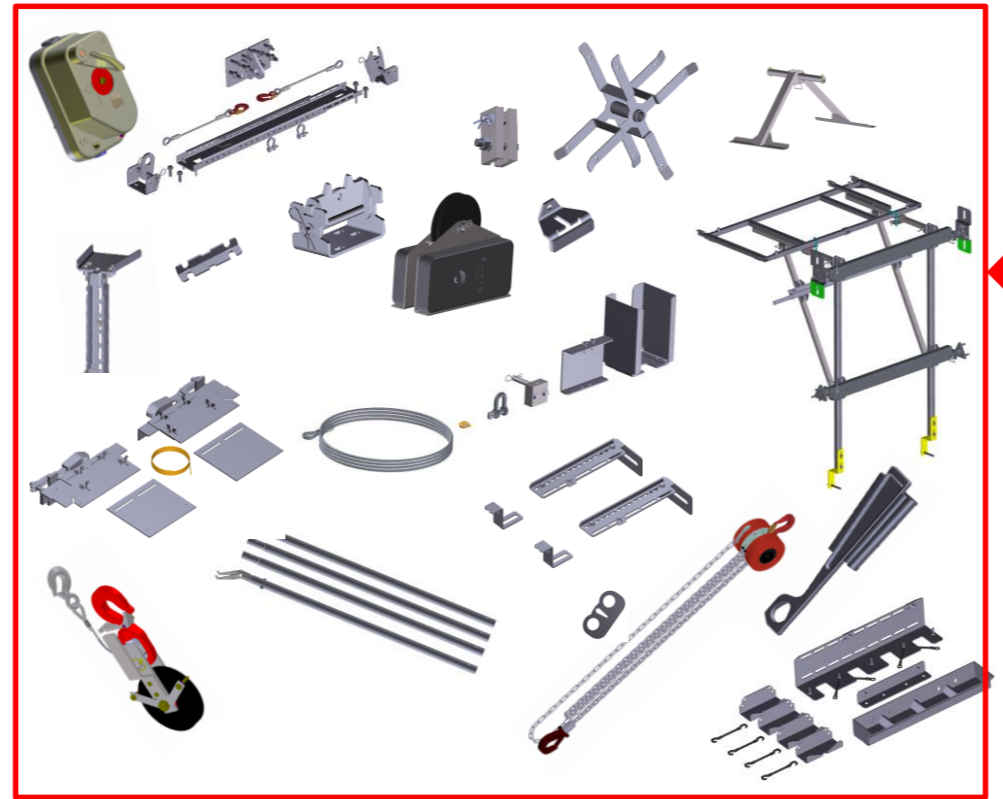
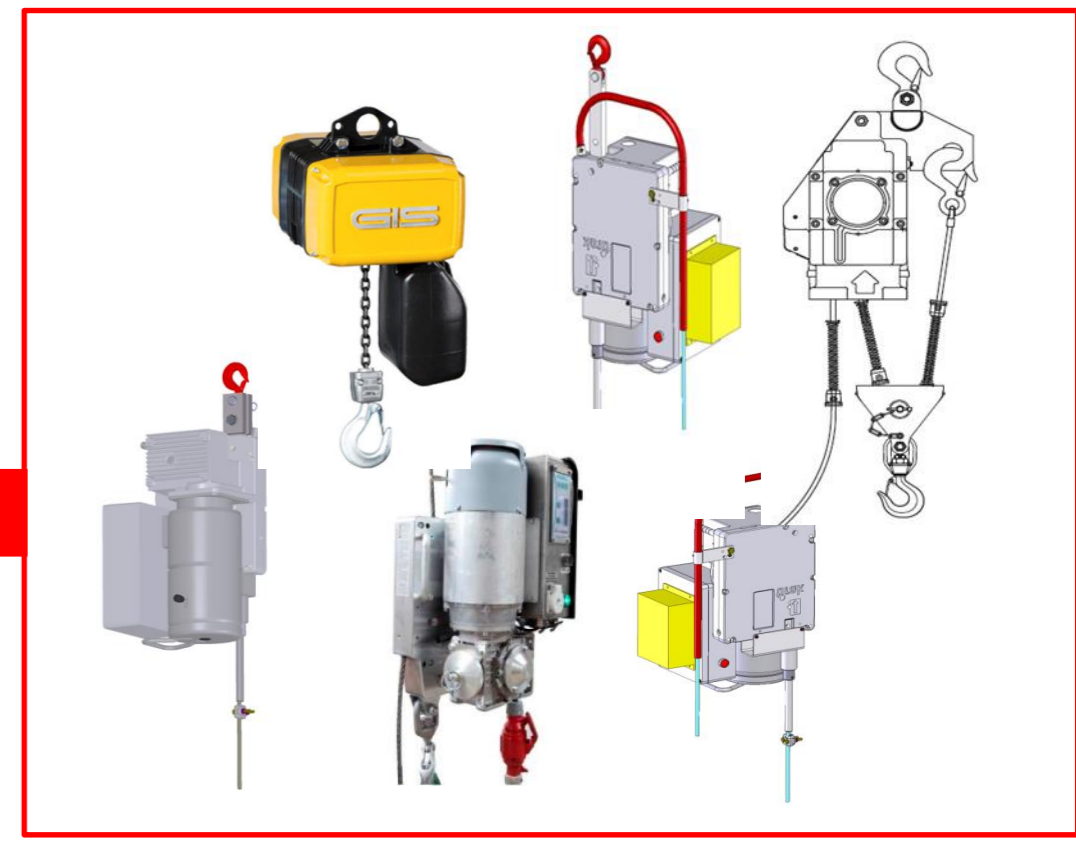

Only One Set of Tools

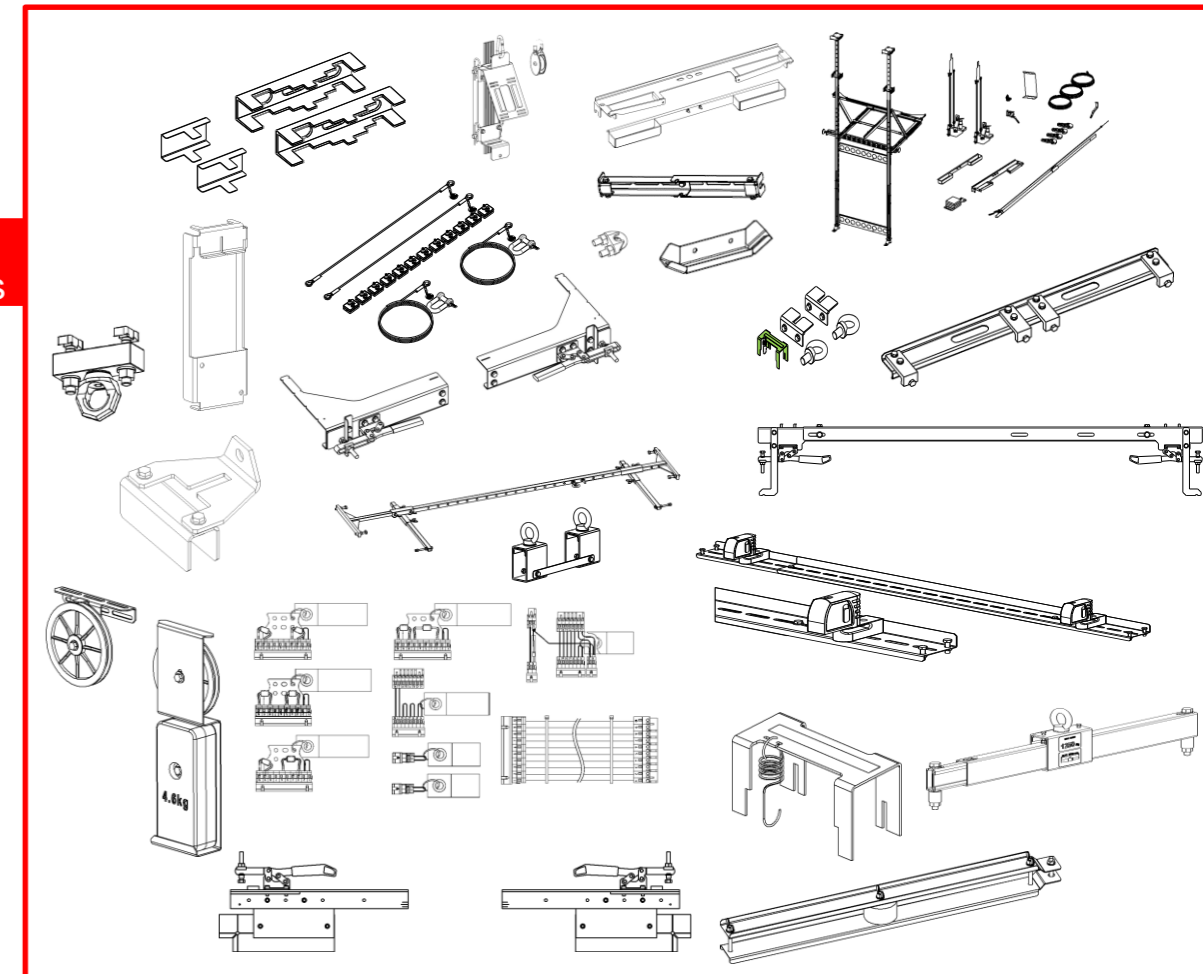

Project Scope & Objectives “INEX”

INEX in a Nutshell

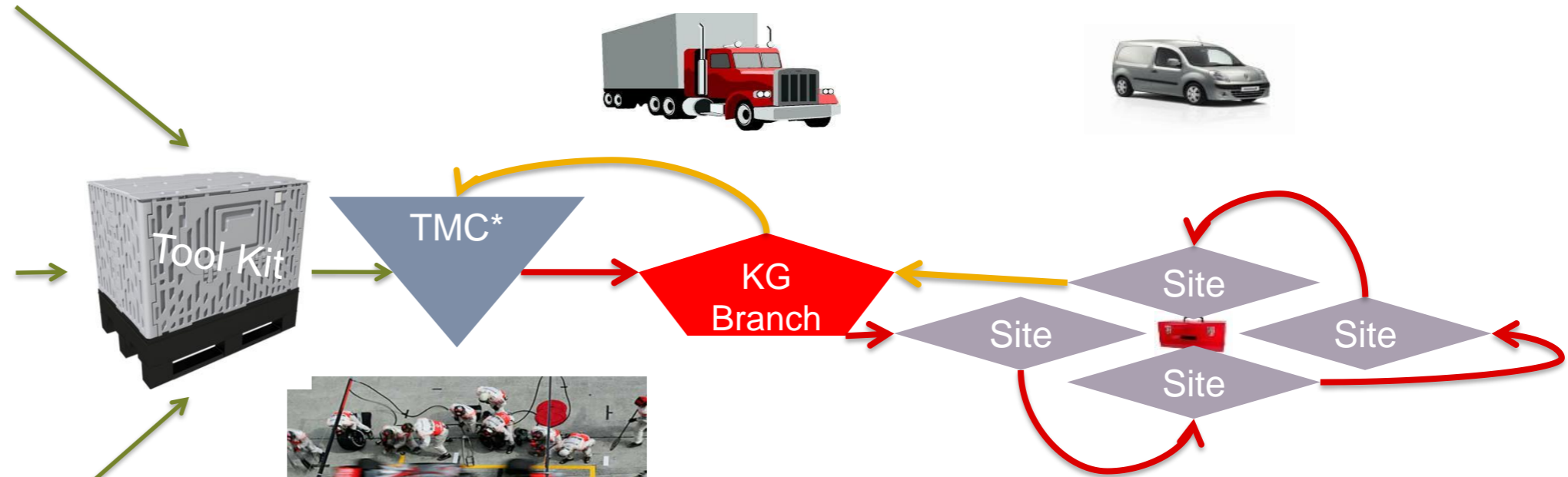
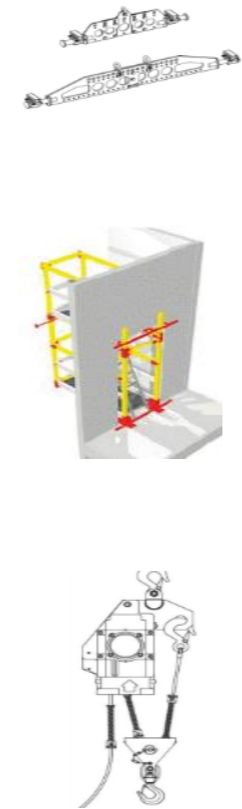
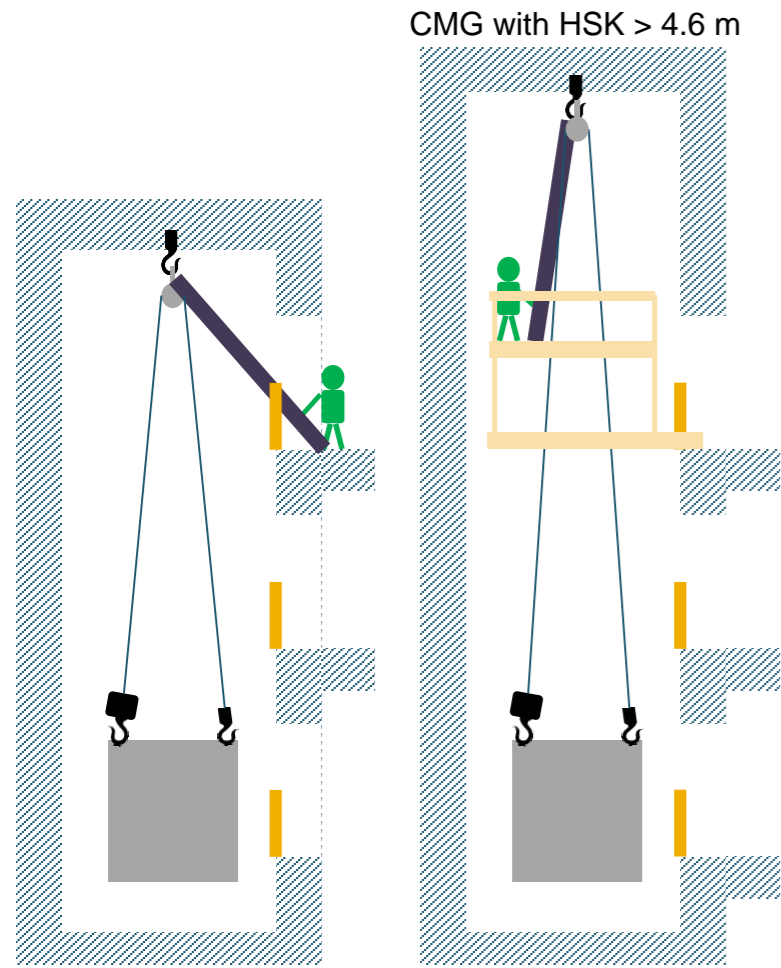
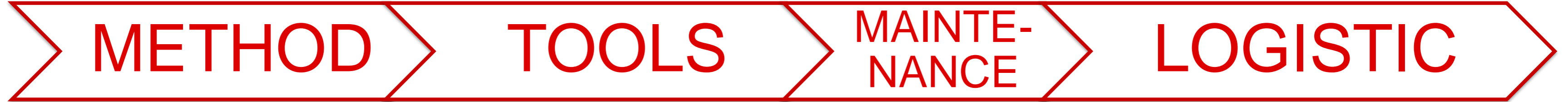

*TMC : Tool Maintenance Center

Advantages:

- Increased safety
- Efficient tool change management for new PLs
- Lower cost in KGs due to:
 - Volume purchasing
 - No individual certification of methods & tools
 - No individual documentation and training
 - No storage cost for tools
 - No maintenance cost for tools
 - Less cost for tool logistic

Tool Logistic & Maintenance

Project Scope & Objectives "INEX"

Tool Logistic

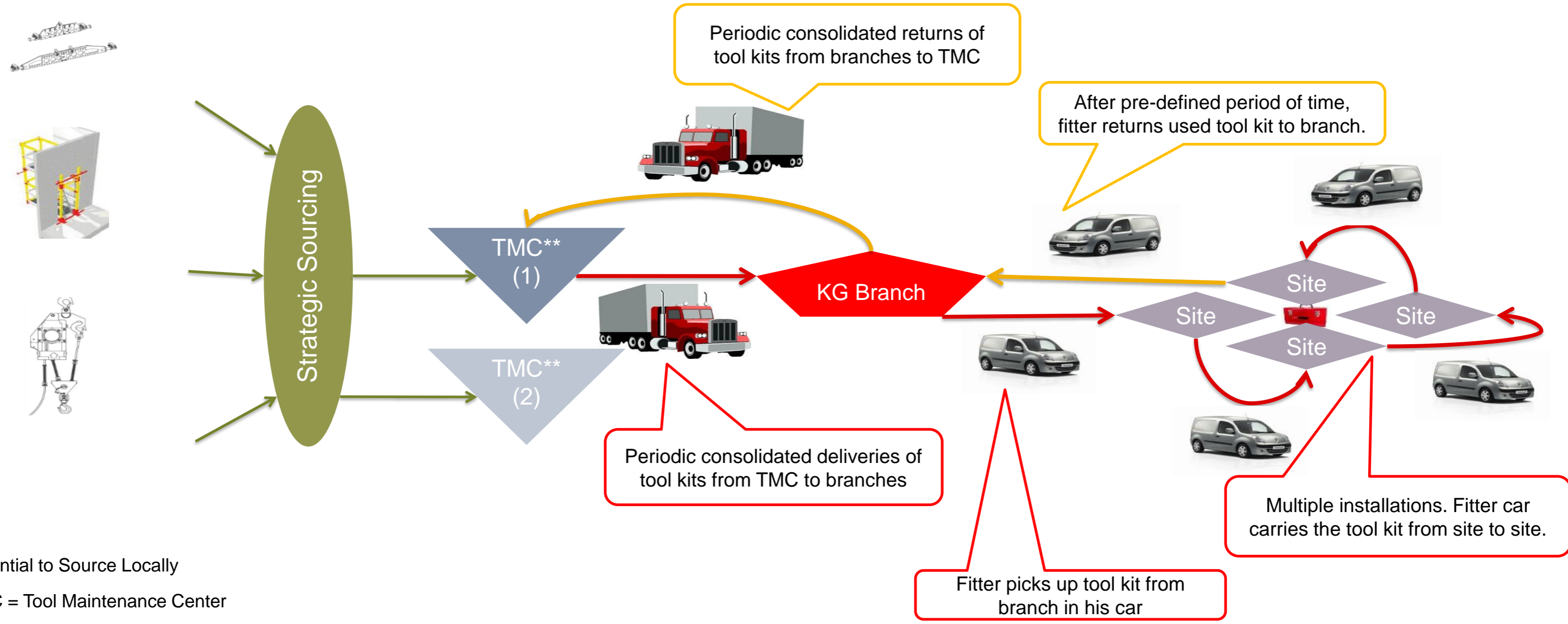
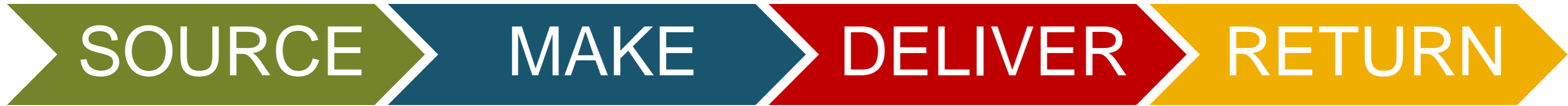

* Potential to Source Locally

**TMC = Tool Maintenance Center